

DeltaPValve™ System Design Manual

The Complete Variable Flow System Approach for HVAC Hydronics

Revision B, October 2003

Abstract

This system design manual illustrates the proper way to apply DeltaPValves and optimize systems with their application. DeltaPValves, introduced to the HVAC market in 1992, are the original pressure-independent, modulating 2-way control valve designed for hydronics applications. Using the approach defined in this manual assures that only the necessary amount (no more – no less) of chilled or heating water is delivered to the cooling and/or heating loads at all times. In turn, this saves energy, increases available plant capacity, minimizes capital expense for additional capacity, and simplifies system design and control.

By: Paul K. Skoglund P.E.
© 2003, Flow Control Industries Inc.

<http://www.flowcontrol.com>

phone: 425-483-1297

fax: 425-486-5672

About the Author:

Paul Skoglund is the founder and president of Flow Control Industries Inc. (Woodinville, WA). He is a mechanical engineering graduate of the University of Washington (1968) and a licensed professional engineer in the states of Alaska, Washington, and Oregon. He has over 35 years experience in the HVAC industry and holds 11 U.S. patents.

Many thanks to Dave Rogers P.E. of Rogers and Associates Inc. (Sacramento, CA) 916-920-5965 for his thoughtful input and support in review of this effort.

Scope

1. This manual is provided as an aid to assist in the design of hydronic systems using DeltaPValves. It will briefly discuss controls, illustrating how proper application of these industrial-quality pressure-independent modulating 2-way control valves saves energy, increases capacity, minimizes capital cost, and simplifies system design and control.
2. This manual is not intended to serve as a guide for selection of other specific components - such things as where to place isolation valves, how to size an expansion tank, when to use thermal storage, how much flow through a chiller, etc. (refer to manufactures recommendations for those details).
3. This manual applies only to the proper piping, coil connections, and control schemes to apply DeltaPValves and capture the resulting benefits. The connections do not vary significantly from conventional design with the application of DeltaPValves. The main differences are 1) balancing valves are no longer required for DeltaPValves in hydronic systems, 2) pressure/temperature ports are standard features on DeltaPValves.
4. The DeltaPValve has the proven track record to back up the design approaches recommended in this manual. **DO NOT USE** this manual as a guide for the application of any other valves.
5. A number of articles are listed in the back of this manual. These reference highlight issues and expenses related to low delta T operations. In addition, they will offer additional insights into piping and pumping systems. Below is our list of existing and growing customers.

Partial Customer List (for Reference)

MIT, Princeton, UCLA, UC Riverside, USC, U. Idaho, U. Colorado Boulder, Colorado State U., U. Missouri, Wichita State U., CSU San Marcos, Grinnell College, Highline Community College, UC Davis Medical Center, North Memorial Hospital, Lutheran Hospital, Children's Hospital L.A., Providence Hospital, National Institutes of Health, VA Hospital Salt Lake, Midway International. Airport, Portland International Airport, JFK International Airport, Boeing, Raytheon, Motorola, Intel, Microsoft, AT&T, Immunex, Amgen, Jaguar, Seagate Manufacturing, Nordstrom Office Tower, Wells Fargo Bank, The British Library, Anacortes Public Library, Seattle Justice Center, Tulalip Casino, Sonoma Development Center

Table of Contents

Page

Abstract	1
Scope	2
Partial Customer List (for Reference)	2
What is Good Performance?	4
DeltaPValve Benefits	5
DeltaPValve Features	6
Hydronics Distribution Systems Key Considerations and Observations	7
Keys to High Delta T	10
Pumping Systems	11
DeltaPValve System Design Principles	13
DeltaPValve Theory of Operation	14
DeltaPValve Coil Piping Schematics	15
DeltaPValve System Pipe Sizing	16
DeltaPValve Selection Procedure	18
Articles on Systems, Hardware, and Low Delta T	19

Appendix A - DeltaPValve System Piping Schematics

Figure A1: Small Heating System – Constant Speed Pump	20
Figure A2: Heating System – Variable Speed Pump	21
Figure A3: Buildings on Large Heating or Cooling Distribution System	22
Figure A4: Small Chiller System – Constant Speed Pump	23
Figure A5: Small Chiller System – Variable Speed Pump	24
Figure A6: Large Chiller Plant – Primary/Secondary Pumping	25
Figure A7: Large Chiller Plant – Primary Variable Flow	26
Figure A8: Typical Campus Piping Schematic – Decoupled Buildings	27
Figure A9: Two-Pipe Changeover System – Excellent for Schools	28
Figure A10: To Address Humidity Issues in Decoupled Labs, Hospitals, Etc.	29

What is Good Performance?

It is imperative for any prospective DeltaPValve customer to quickly recognize the difference between poor and good system performance. The following two charts illustrate chilled water system performance expected with DeltaPValves. The first chart also illustrates the poor performance typically seen in most systems.

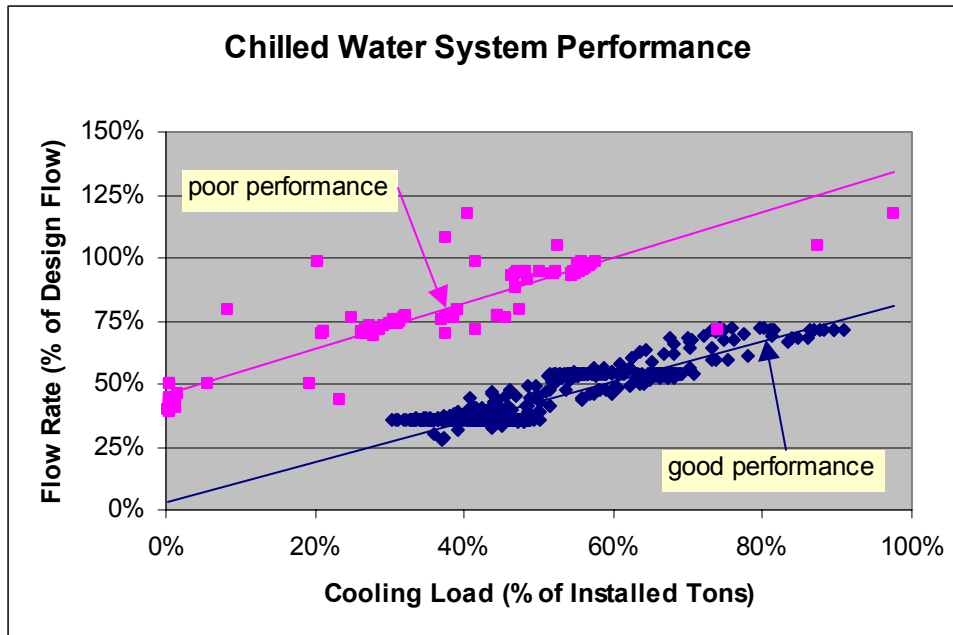

Note that substantially less flow is required when DeltaPValves are installed. In contrast between 70% and 120% flow is used to address 40% of the cooling load in a conventional system.

Figure 1: % Cooling Load vs. % Flow Rate

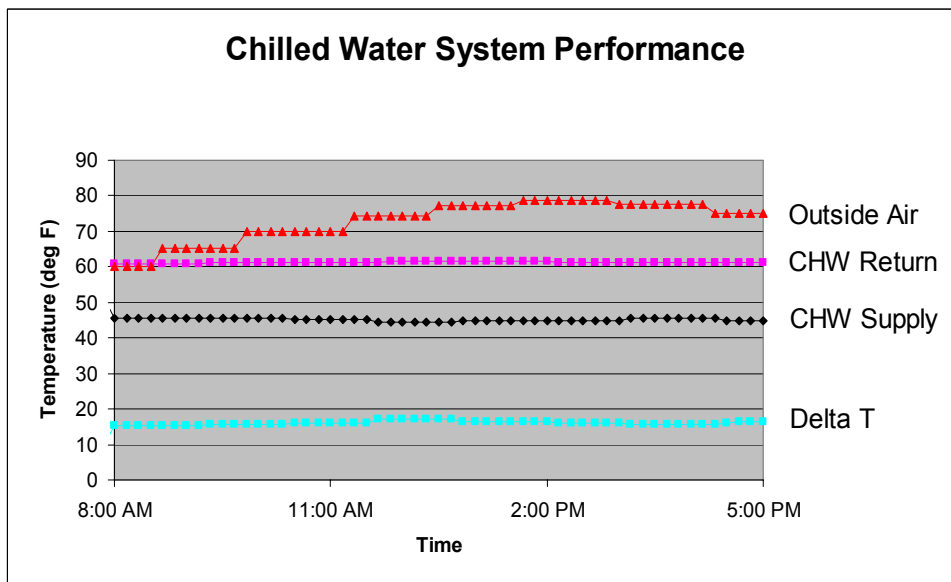

In this system the coils are selected for both 10 to 12 degrees delta T yet with DeltaPValves it delivers between 16 and 19 degrees delta T as the outside air temperature varies between 60 and 80 degrees. This level of performance is very rare in most systems.

Figure 2: Building Chilled Water Performance Trend

DeltaPValve Benefits

Minimize capital expenses

- Full diversity permits less capacity investment
- Minimum flow per ton reduces pipe size
- Reverse return piping not required
- Fewer pumps and less installed pump horsepower
- Variable primary flow easily achieved
- Simplified design and control
- Performance risk minimized at startup

Minimize maintenance and operating expenses

- Cut power demand and energy consumption
 - raising delta T reduces gpm/ton cooling, decreases pump head and flow, eliminates return water blending, fully loads chillers, minimizes accessory energy, reduces air-side fan energy
- Eliminate ongoing system balancing
- Minimize excess flow and operation of hydronic equipment
- Permit reduced air flow through air handling equipment

Tackle outstanding issues

- Control valve hunting
- Low delta T
- Excess flow
- Wasted energy
- Limited capacity (flow limited plant, building coils)
- Poor temperature and humidity control

Visualize the results

- Measure as well as control flow

DeltaPValve Features

DeltaPValves are available for hot water, chilled water, and glycol in design flows from 1 to 4000 gpm and sizes between ½” and 14.”

Standard Features

- Pressure Independent Operation
- Automatic Dynamic System Balancing
- Adjustable Cv
- 100:1 Rangeability
- +/- 3% Flow Variation at Each Position through Operating Pressure Range
- Full Pressure Rating Shutoff
- Low Torque Operation
- 5 Year Warrantee
- 3 P/T Ports (for system measurement, VFD control, and troubleshooting)
- Flow Tag with Measured Flow vs. Position
- No Plastic Parts

Available Options

- 5-60 psi or 10-90 psi Differential Pressure Operating Range
- 150 or 300 psi Rating
- Electric, Pneumatic or Manual Control
- 3-point, Modulating, and Fail Safe Operation
- Weather Covers
- P/T Port Extensions
- Metric Adapters

Hydronics Distribution Systems

Key Considerations and Observations

Steady Flow is Better than Unsteady Flow. Heat transfer effectiveness for a cooling coil is greatest with steady flow. Wide swings in flow in support of a given cooling or heating load reduce effectiveness and cause the control valves to command more flow. Standard, commercial-quality control valves and controls cannot sustain steady flow, particularly at part load.

Control Valves, Not the Coil, Set the Delta T. Delta T is the temperature difference between supply and return water across a cooling or heating coil. The only point where the coil sets the water delta T is at design conditions – at all other loads the control valve sets the delta T. Most coils are oversized – they are only available in so many rows, fins/inch, etc. The designer usually selects a cooling or heating coil with excess capacity to insure the design load is satisfied and, as a result, the coil has excess capacity.

High Chilled Water Supply Temperature (CHWST) Increases both Pump and Fan Energy. When the CHWST is allowed to rise (either from chiller reset or return water blending) delta T decreases and both pump and fan energy rise to address the cooling load. This increase in energy consumption per ton cooling commonly overwhelms any savings in chiller energy and may lead to temperature/humidity control problems and system capacity issues.

High Delta T Minimizes Energy Consumption. For a given heating or cooling load, when flow is excessive, ΔT is low. A well functioning system should demonstrate low flow and high ΔT at all system loads to minimize the energy consumed in producing and distributing hot and chilled water.

$$Gpm = \frac{Tons * 24}{\Delta T}$$

Example 1: 1000 ton installed capacity, 800 ton cooling load, 12°F ΔT design (with 8 and 16 degree system delta T performance)

$$\frac{800 * 24}{8} = 2400gpm \qquad \frac{800 * 24}{16} = 1200gpm$$

High Delta T Increases Available System Capacity in a Flow Limited Plant. Chillers have a maximum flow limit typically designed to deter evaporator tube erosion. Primary pumps are commonly sized to this flow limit. As shown below, for a fixed maximum evaporator flow, low ΔT limits the available capacity (Flow Limited Plant).

$$Tons = \frac{Gpm * \Delta T}{24}$$

**Example 2: 1000 tons installed capacity, 2000 gpm max flow, 12°F ΔT design
(with 9 and 12 degree system delta T performance)**

$$\frac{2000 * 9}{24} = 750 \text{ tons}$$

$$\frac{2000 * 12}{24} = 1000 \text{ tons}$$

50% Flow = 80% Heat Transfer. The theoretical performance of a cooling coil is illustrated in Figure 3 below. Note that half the chilled water flow addresses 80% of the cooling load. Hot water coils demonstrate similar trends. This proves to be the actual case when DeltaPValves are used. Since many coils are 10-20% oversized, and loads are typically less than 80%, flow should seldom exceed 50% of design. Delta T should rise, not fall, at loads less than 100% reducing the gpm/ton required for cooling.

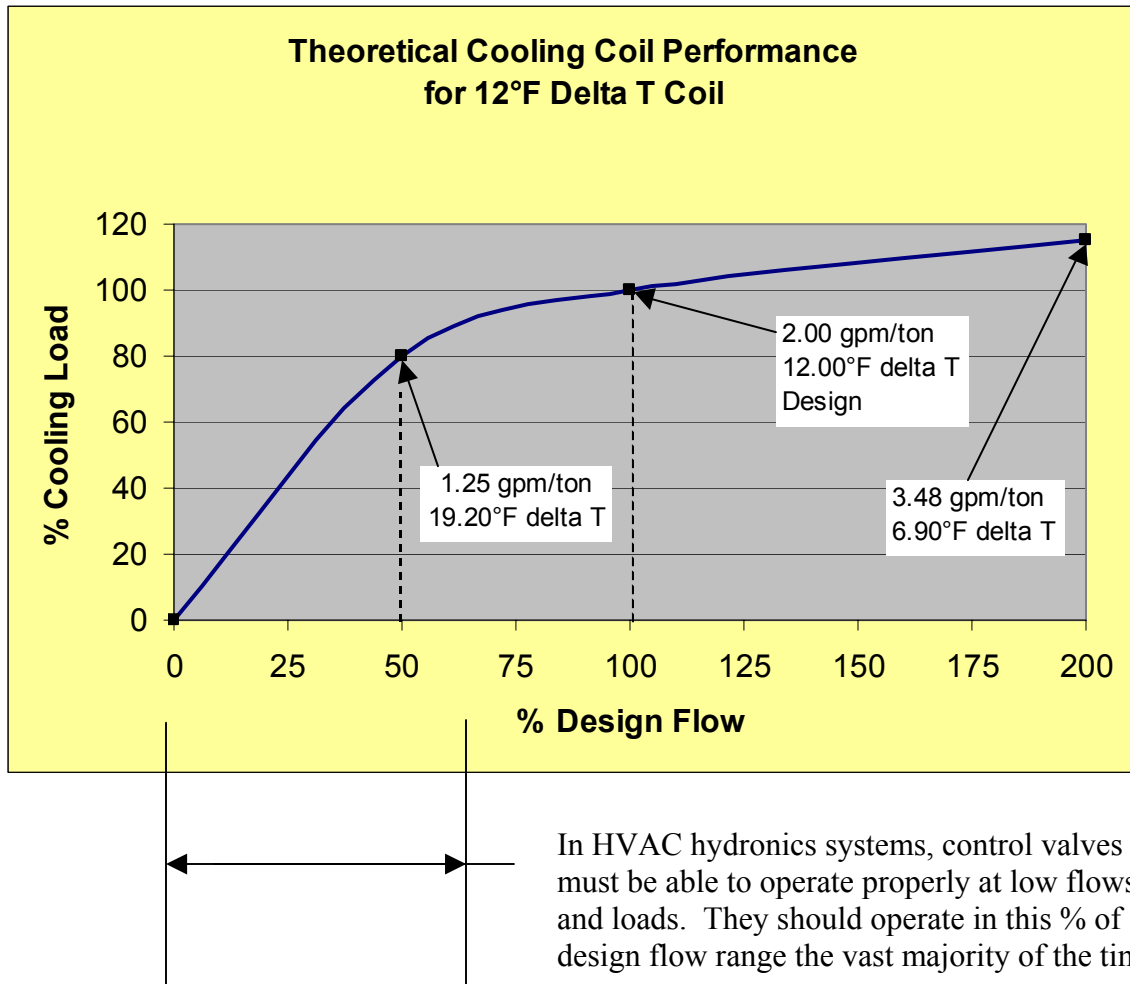

Figure 3: Cooling Coil Theoretical Performance

High Delta T Minimizes Flow and Decreases Pump Energy. As the pump affinity laws below illustrate, horsepower is a cube root function of the flow. Bear in mind that pump affinity laws apply to pumps only and not directly to systems.

Pump Affinity Laws

$$\frac{P_2}{P_1} = \left(\frac{Q_2}{Q_1}\right)^2 \quad \frac{HP_2}{HP_1} = \left(\frac{Q_2}{Q_1}\right)^3$$

where: Q = Flow (gpm), N = Pump Speed (rpm), P = Pressure (psi), HP = Power (horsepower)

Example 3: Assume $Q_1 = 3000$ gpm, $P_1 = 40$ psi, $HP_1 = 100$ hp and that flow has been successfully reduced to address a given cooling or heating load. $Q_2 = 1500$ gpm.

$$P_2 = \left(\frac{Q_2}{Q_1}\right)^2 P_1 \quad \text{1/2 flow} = \text{1/4 pump head}$$

$$P_2 = \left(\frac{1500}{3000}\right)^2 * 40 = 10 \text{ psi} \quad \text{head reduced by 30 psi}$$

$$HP_2 = \left(\frac{Q_2}{Q_1}\right)^3 HP_1 \quad \text{1/2 flow} = \text{1/8 pump hp}$$

$$HP_2 = \left(\frac{1500}{3000}\right)^3 100 = 12.5 \text{ hp} \quad \text{pump power reduced by 87.5 hp}$$

The example above is for pumps only and is not a systems calculation. As such, it does not take into account the additional reduction in condenser pump energy that results from achieving design delta T or greater. High delta T eliminates the excess operation of additional chillers and their accessories (no flow limit), and excess flow through “dead” chillers or flow through primary/secondary or secondary/tertiary bypass piping.

Keys to High Delta T with minimum energy, operation, and capital investments

Facilities owners should always correct low ΔT issues before unnecessarily investing in new capacity. Many systems are modified (more pumps, larger pipes, additional chillers, thermal energy storage, added controls, etc.) when simply applying DeltaPValve principles will address the issues at a far lower cost and provide added long term energy and operational savings.

High chilled water ΔT is the key to outstanding chilled water system performance. While much is written about addressing energy and capacity problems related to low ΔT , few recommendations are as simple and effective as the following:

DO'S

- 1) Remove 3-way valves and unnecessary bypasses in all variable flow distribution systems.
- 2) Ensure that heat transfer surfaces are clean – replace bad coils and heat exchangers - select coils at design conditions for a minimum of 4 fps tube velocity on varying load applications.
- 3) Steady the flow with DeltaPValves to maximize the heat transfer.
- 4) Select modulating electronic (vs. pneumatic) actuators whenever possible for best control.
- 5) Simplify controls.
 - a. Maintain the minimum required pressure (typ. 5 psi) across the hydraulically most remote valve(s).
 - b. Use thermostat (typically room or supply air) to control flow through DeltaPValves in most installations.
- 6) Use VFD's or mechanical speed adjustment with DeltaPValve systems to minimize pump energy. In small systems, ride the constant speed pump curve with DeltaPValves.
- 7) Remove excess system pumping horsepower - use a check valve in a bypass line to bypass building pumps that are not required at part load - pump coils for freeze protection only.
- 8) Protect chilled water supply temperature and leaving air temperature setpoints. Heat transfer is more effective with a higher spread between entering water and supply air temperature.
- 9) Close control valves when AHU fans are off unless required for freeze protection.
- 10) Specify and monitor coil return water temperature and corresponding system delta T - it should never be less than design delta T under any load condition when the above steps are taken.

DONT'S

- 1) Permit reset of supply air temperatures below design conditions
- 2) Permit reset of supply chilled water temperatures above design leaving water temperature from the plant when more than one chiller is running and temperature or humidity control is an issue. Pump and fan energy consumption per ton cooling will commonly rise in excess of any chiller energy savings. Chiller and coil capacity will decrease.
- 3) Permit significant return water blending with supply.
- 4) Pump coils to try to raise delta T back to the central plant.
- 5) Make a practice of using coils in series to raise delta T - this wastes fan energy, costs more initially, and is unnecessary.
- 6) Decouple buildings to raise delta T.

Pumping Systems

Constant Speed Pumping System

As shown in Figure 4, in constant speed pumping systems, additional pressure must be absorbed across the control valve at partial flow. At full design flow, the control valve pressure drop is minimal. Conventional commercial-quality, low rangeability 2-way globe valves modulate poorly below 40% of full rated flow and tend to operate as a two-position (on-off) valve at low percentage flows.

Remember that 50% flow = 80% heat transfer; therefore, flow should be below 50% for the majority of heating and cooling load conditions.

Constant Speed Pumping System

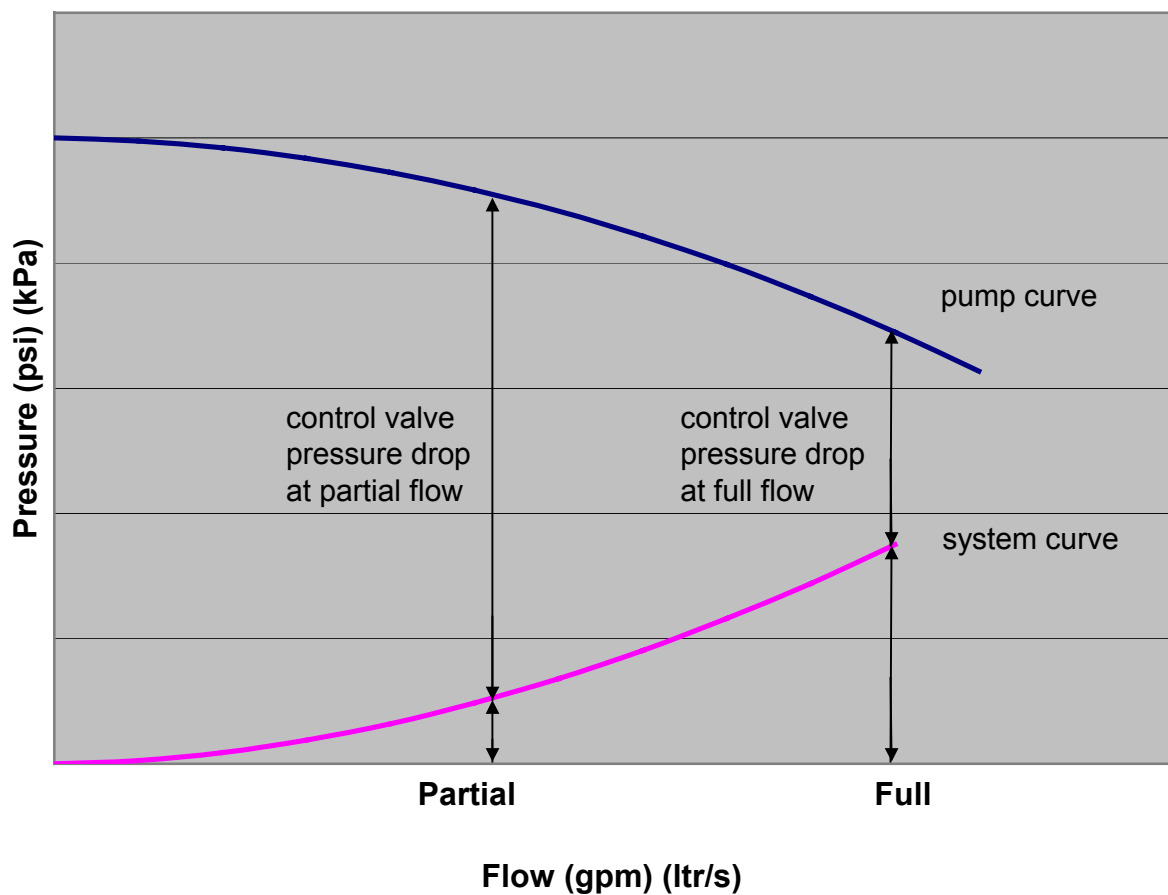

Figure 4: Constant Speed Pumping

DeltaPValves work very well on constant speed pumping systems. Flow is not affected by changing pressure and the valves modulate accurately from 0 to 100% full rated flow.

Variable Speed Pumping System

Variable speed pumping is recommended when loads vary and pumps run below full rated flow most of the time. Large piping systems see wide fluctuations in pressure even when variable speed pumping systems are utilized. Variable speed pumping used in conjunction with DeltaPValves optimize system performance and minimize energy consumption. At full flow, the pressure drop across all valves is the same for constant and variable speed pumping systems. The valves near the pump still see high differential pressure. Good Delta T performance allows the pump to move down the control curve.

Variable Speed Pumping System

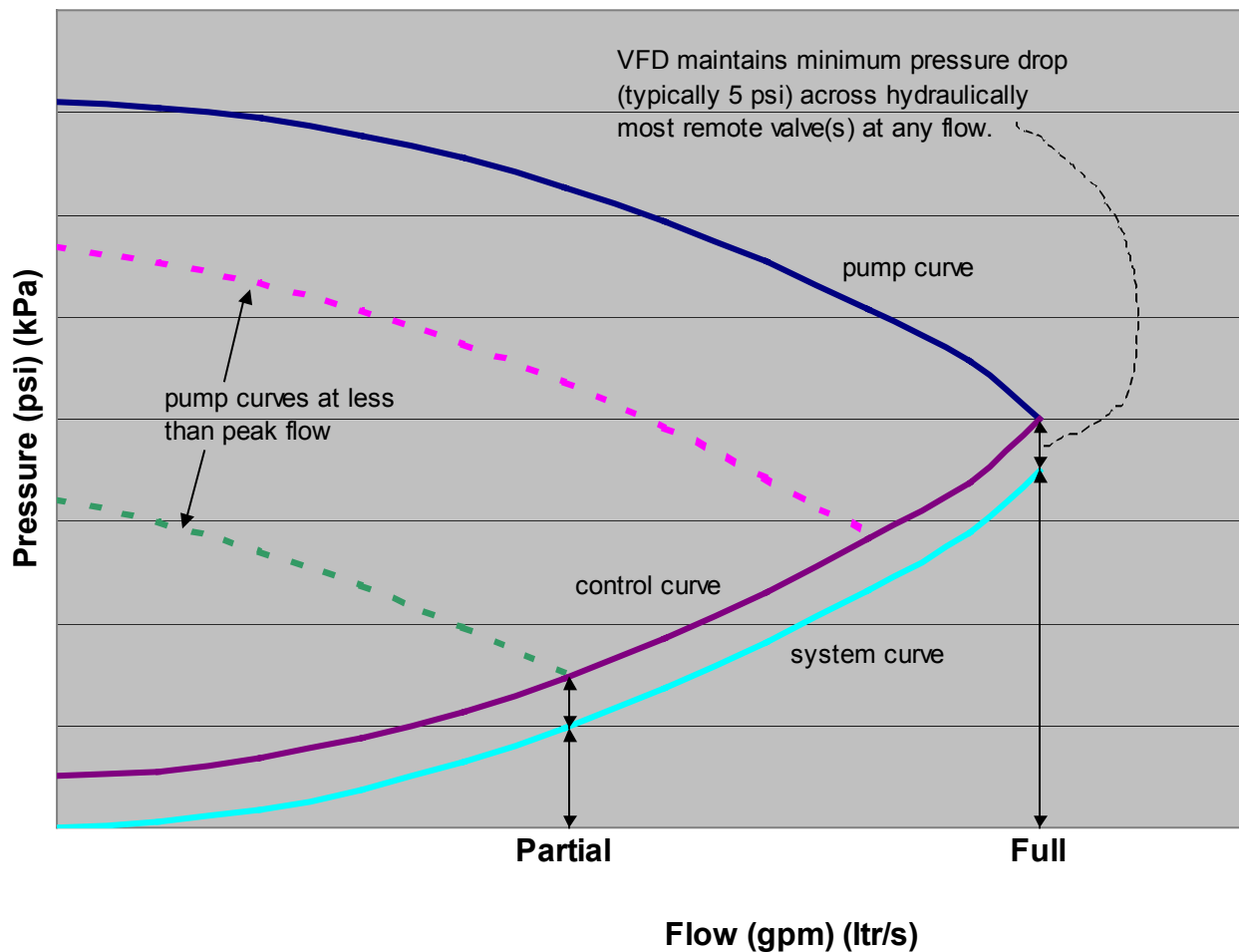

Figure 5: Variable Speed Pumping

Note: Most systems, even with VFD and other sophisticated controls, suffer from low delta T. This is because none of these components is designed to precisely match flow to the cooling load at each individual coil at all load conditions.

DeltaPValve System Design Principles

Downsize and Eliminate Excess Equipment

1. No balancing valves for DeltaPValve applications.
2. No reverse return piping.
3. Minimize installed and utilized system pumping horsepower.
4. No unnecessarily complicated controls (tuned PID loops, etc.).
5. Smaller pipes with high delta T and less circulated water.
6. Full installed capacity delivered (no Flow Limited Plant).

Minimize Capital Costs

In existing systems, don't purchase additional equipment capacity until low delta T issues are addressed and the additional capacity is really required. DeltaPValve retrofits are far more cost effective than new pumps, chillers, thermal energy storage, sophisticated controls, and bigger piping and lead to long term operational cost savings.

Minimize Installed and Utilized System Pumping Horsepower

Minimize the use of pumps. They require space, power, maintenance etc. There is no longer a requirement to use a lot of pumps to distribute the pressure gradients of hydronic systems. The DeltaPValve performance is not affected by high differential pressures across it or varying pressures in that occur dynamically all the time that they operate.

This manual doesn't recommend the actual number of pumps other than to keep them to a minimum. Load profiles need to be considered to determine pump staging and sizing. Each system must be evaluated on it's own merits.

Design the piping system. Our old rules-of-thumb are too expensive. Today's piping installations are in general is larger than required. Later in this manual we give recommended rule of thumb pipe sizing when applying DeltaPValves.

Maximize Delta T in Design and Operation – Minimize Operating Costs

Continued excess energy costs are incurred with systems operations that are producing low delta T. The life cycle costs for these applications are high with no added benefit for the facility owner. Low system delta T also limits available system capacity (Flow Limited Plant). The following are recommended **system** design delta T's for heating and cooling applications.

- a. Design for 40 to 60°F delta T in heating systems.
- b. Design for 18 to 24°F delta T in cooling systems. Even higher in some applications.
- c. Measure and monitor system and coil delta T's during system operation - seek 1.25 times design coil delta T or better for part load performance.

DeltaP Valve Theory of Operation

DeltaP Valves are pressure-independent, modulating 2-way control valves. Figure 6 is a schematic that illustrates operation of DeltaP Valves. Figure 7 is a graph illustrating pressure-independent valve performance.

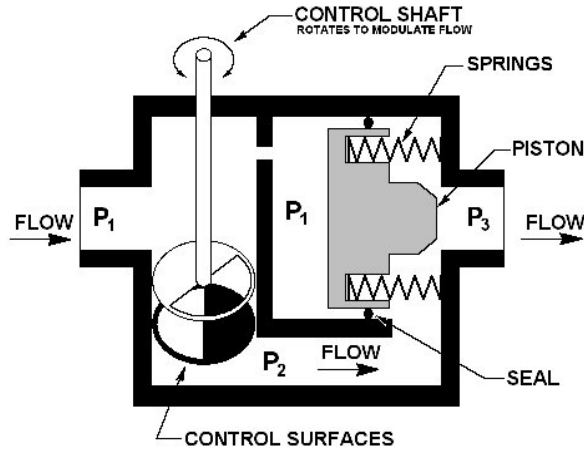

Figure 6: DeltaP Valve Schematic

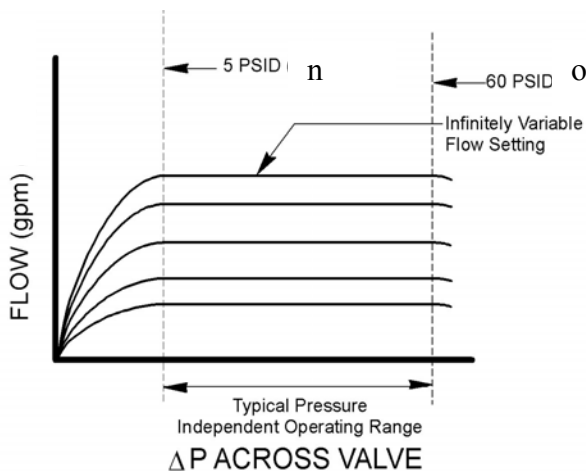

Figure 7: DeltaP Valve Performance

DeltaP Valves are used to control water flow. These fully modulating two-way flow control valves are completely PRESSURE INDEPENDENT. “Pressure independent” means that the flow rate remains constant as differential pressures fluctuate across the valve. DeltaP Valves have two critical sections:

The first section is the Cv section. This section changes the flow rate through the valve as the Cv is changed (by rotating the valve stem manually or with an electric or pneumatic actuator). The Cv section may be compared to any high quality two-way modulating valve.

The second section is the differential pressure section. The spring and piston in this section functions to maintain a constant differential pressure (P1-P2) across the control surface using only the internal fluid pressures in the DeltaP Valve. Thus the flow rate is unaffected by pressure changes (P1-P3) across the valve.

In contrast with pressure dependent control valves, DeltaP Valves do not hunt. The actuator strokes to change the flow only in response to a demand for more or less heating or cooling.

Very Important! Steady flow (in spite of system pressure changes) is the key to excellent heat transfer performance. Minimum flow and high delta T is the result.

DeltaPValve Coil Piping Schematics

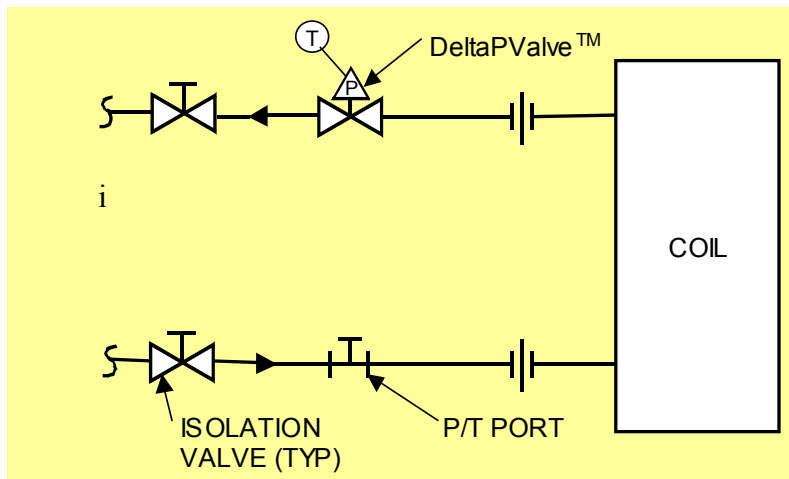

Return water temperature sensing to building management system (BMS) is recommended. Flow is directly related to actuator rotation position and is recorded on the valve tag.

Figure 8: DeltaPValve with Typical Coil

DeltaPValves guarantee design ΔT through coil, provided “Keys to High Delta T” on Page 10 are followed.

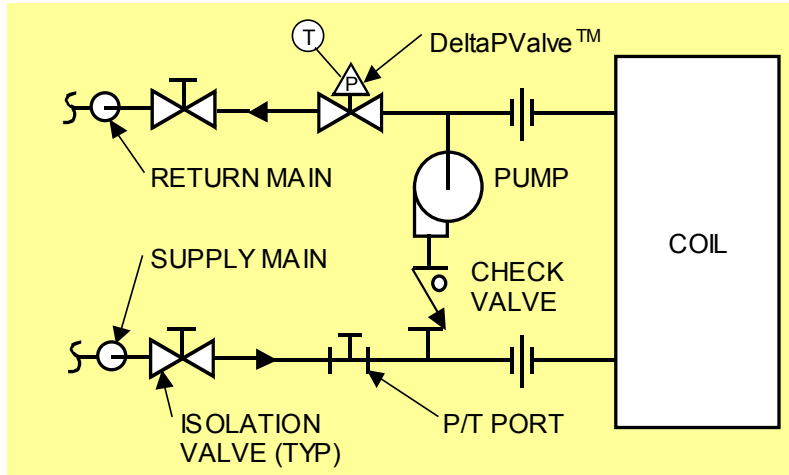

FOR FREEZE
PROTECTION
ONLY

Figure 9: Pumped Coil Schematic

Pump 25% of coil design flow for freeze protection.

DeltaPValve System Pipe Sizing

First cost (piping) and system operating cost (from friction head loss) should be considered together. Using DeltaPValves considerably reduces the flow required to address heating and cooling at part loads; therefore, higher pipe velocities at design conditions may be considered to reduce first cost. Part loads constitute the vast majority of operating hours in most systems. Engineers typically have a 10 to 20% safety factor built into their designs. Therefore the chances of ever requiring design flows are slim. Remember 50% flow = 80% heat transfer as shown in Figure 3.

Tables 1 and 2 show the recommended flow rates, velocity, and pressure drop for copper and schedule 40 iron pipe at the conventional and higher fluid velocities.

Typical current practice is to size smaller pipe at 4.5 ft/100 ft pressure drop and larger pipes to a maximum fluid velocity of 10 ft/sec. This is shown in Table 2. ASHRAE Research Project RP-450, Water Flow Rate Limitations, investigated current industry practice and found that much higher velocities (17 ft/sec) can be used without erosion, corrosion, or noise problems – provided that effective air control is maintained.

Table 1: Pipe Sizing Table (1/2” to 1-1/2” L-Type Copper)

Nominal Pipe Size	Low			High		
	Gpm	Ft/Sec	Ft/100Ft	Gpm	Ft/Sec	Ft/100Ft
1/2”	1.5	2.1	5.5	3	4.1	20
3/4”	4	2.7	5.5	7	4.6	16
1”	8	3.1	5.0	15	5.8	16
1-1/4”	14	3.6	5.0	25	6.4	15
1-1/2”	22	4.0	5.0	40	7.2	15

Table 2: Pipe Sizing Table (2” to 24” Schedule 40 Iron Pipe)

Nominal Pipe Size	Low			High		
	Gpm	Ft/Sec	Ft/100Ft	Gpm	Ft/Sec	Ft/100Ft
2”	44	4	3.2	80	8	13.5
2-1/2”	78	5	4.3	125	9	10.5
3”	135	6	4.6	235	10	13.0
4”	240	6	3.6	470	12	12.2
5”	510	8	4.6	900	15	14.0
6”	810	9	4.2	1500	17	14.0
8”	1600	10	3.8	2700	17	10.5
10”	2400	10	2.8	4050	17	7.5
12”	3500	10	2.7	5700	17	6.0
14”	4200	10	2.2	7000	17	5.5
16”	5500	10	1.8	9500	17	4.5
18”	7100	10	1.5	12500	17	4.1
20”	9000	10	1.3	14000	17	3.6
24”	12700	10	1.1	22000	17	2.8

Pipe Sizing Notes

1. These piping charts are guidelines only. For example, if you have a campus system with long runs of pipe connecting the buildings you would:
 - a. Size the piping inside the building smaller (on the high side of Tables 1 and 2, page 16).
 - b. On large campuses, size the long piping runs connecting the buildings larger (on the low side of Table 2, page 16) to reduce the pressure drop in the mains so you won't have to use additional pumps in the buildings – this also retains capacity in the mains to serve additional connected loads in the future.
2. On existing large systems it is a good practice to create a system model using a piping program. This topic is far larger than represented here. Keep in mind that these programs model systems relatively well when they are performing as designed but seldom address excess flow and low delta T at part load.

While there are many piping programs available, the program we have used successfully is Pipe-Flo[®] (Engineered Software, Olympia, WA, 1-800-786-8545).

DeltaPValve Selection Procedure

Valve Selection

1. Determine the max. flow rate (gpm) required (usually design from coil schedule).
2. Determine the maximum differential pressure that the valve will work against (normally the design head of the pump serving that circuit).

The standard DeltaPValve operates in the range from 5 to 60 psi differential using a 5 psi spring. Higher spring ranges (10 and 15 pounds) are available that will handle up to a 150 psi differential. If the valve is close to the pump and will always have a minimum of 10 psi across it to drive it, you can sometimes get by with a smaller valve (because higher spring rates allow higher flow for the same size valve) to serve the load.

3. Determine the maximum static pressure the valve will encounter to establish the required body pressure rating (150 or 300 psi).
4. Go to the catalog to determine the size and model number of the valve.
5. Determine coil tag description (i.e. AHU-1, FCU-3) for the valve tag.

Actuator Selection

1. Determine what type of actuator you require. Electronic or pneumatic are available. All valves take a 0 to 90 degree rotating actuator. Linkages for pneumatic valves are similar to pneumatic duct dampers connections.
2. Using the DeltaPValve catalog, size the actuator for the maximum differential pressure (#2 above) plus a 50% safety margin.
3. Determine if you want fail safe operation. Standard modulating (proportional) actuators are recommended for all chilled water applications. We recommend that electronic proportional actuators on chilled water valves fail in place as opposed to fail open or fail closed.
4. Determine the action (normally open or normally close) for all actuators and the fail position (open or closed) for pneumatic and electronic fail safe actuators.
5. Choose the control signal for the actuators. Typically 2-10 vDC and 4-20 mA for electronic control and spring range (psi) for pneumatic control.

Accessory Selection

1. Determine if weather covers, P/T plug extensions, metric adaptors, or any other special features are desired.

Articles on Systems, Hardware, and Low Delta T

The following articles are intended to provide additional information related to the topics presented in this manual. A number of these articles illustrate the issues with substandard delta T performance. Some of these articles, although deficient in providing a simple and comprehensive approach to address specific low delta T issues, are provided to illustrate the contrast of the DeltaPValve approach.

1. Rishel, James B., "Is Your Chilled Water System Ready For Adaptive Control," Engineered Systems, February 2003.
2. Skoglund, Paul K., "Control Your Chilled Water – Save Energy, Increase Capacity," IDEA Conference Paper, Austin, TX, February 13, 2003.
3. Kreutzmann, Jim, "Campus Cooling: Retrofitting Systems," HPAC Engineering, July 2002.
4. Taylor, Steven T., "Primary-Only vs. Primary-Secondary Variable Flow Systems," ASHRAE Journal, February 2002.
5. Rogers, David A. and Lewis, Michael S., "A New Congeneration Plant – The University of California Davis Medical Center Sacramento – A Case Study," IDEA Conference Paper presented in Denver, CO February 28, 2002.
6. Mazurkiewicz, Greg, "Manufacturer Improves Absenteeism, IAQ with HVAC Retrofit," ACHR News, published January 7, 2002.
7. Lunneberg, Tom, "Varying Chilled Water Flow with Constant Success," E-Source Article ER-01-11, July 2001.
8. Fiorino, Donald P., "Achieving High Chilled-Water Delta T's," ASHRAE Journal, November 1999, vol. 41, no. 11.
9. Brown, Brian, "Klamath Falls Geothermal District Heating Systems Evaluation," <http://geoheat.oit.edu/bulletin/bull17-3/art22.htm> downloaded January 21, 2003.
10. Skoglund, Paul K., "Hydronic Systems Benefit from Pressure Independent Flow Control Valves," District Energy, First Quarter 1995.

Appendix A: DeltaPValve System Piping Schematics

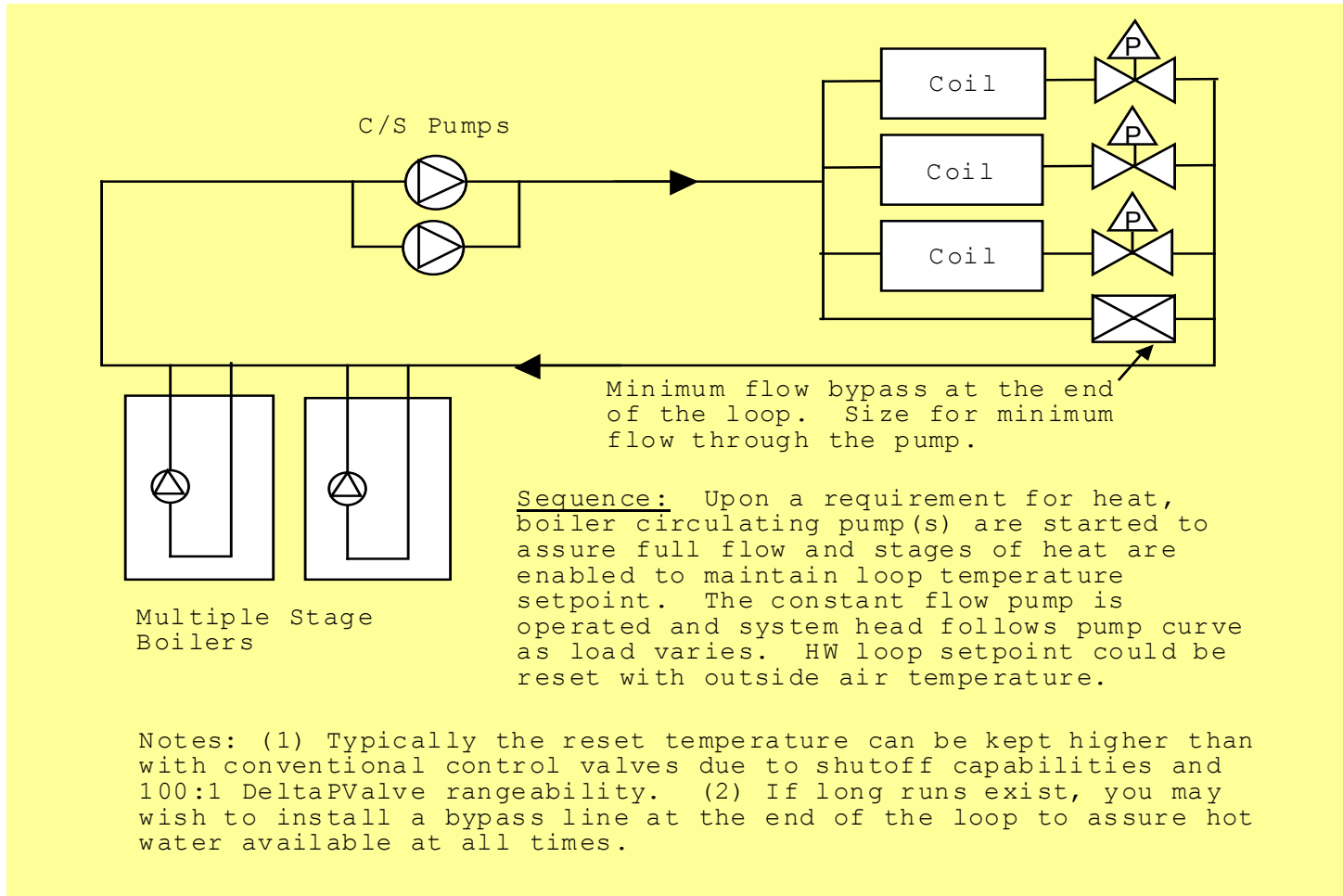
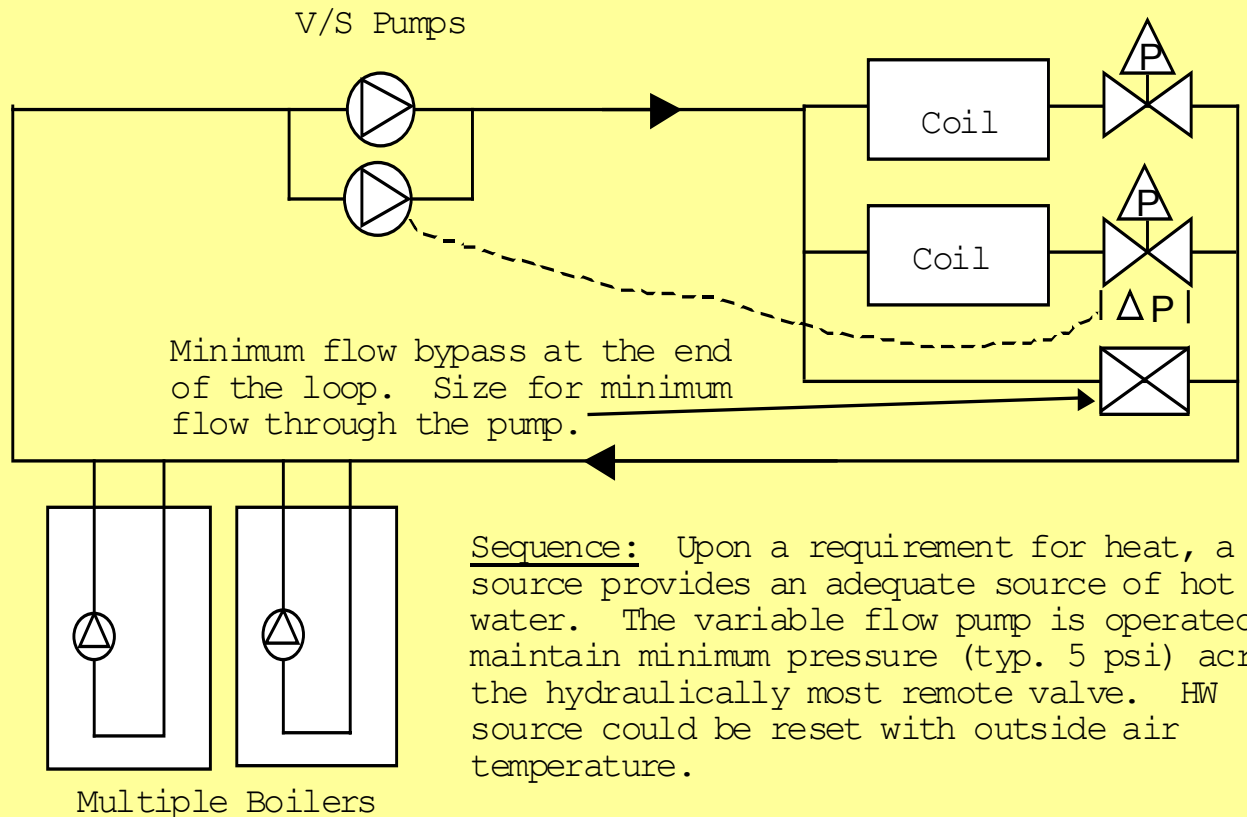

Figure A1: Small Heating System - Constant Speed Pump



Notes: (1) Typically the reset temperature can be kept higher than with conventional control valves due to shutoff capabilities and 100:1 DeltaPValve rangeability. (2) If long runs exist, you may wish to install a bypass line at the end of the loop to assure hot water available at all times.

Figure A2: Heating System – Variable Speed Pump

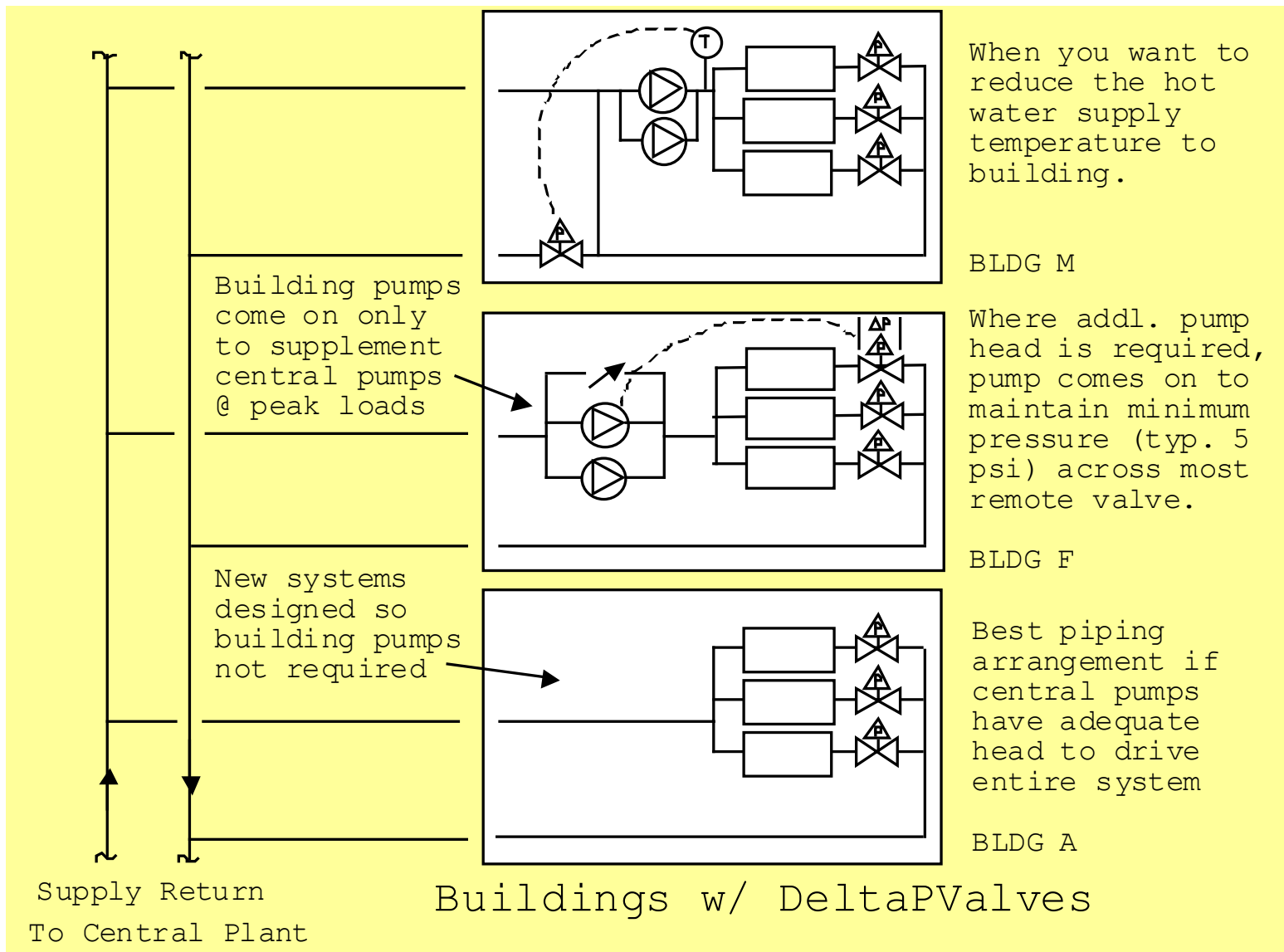
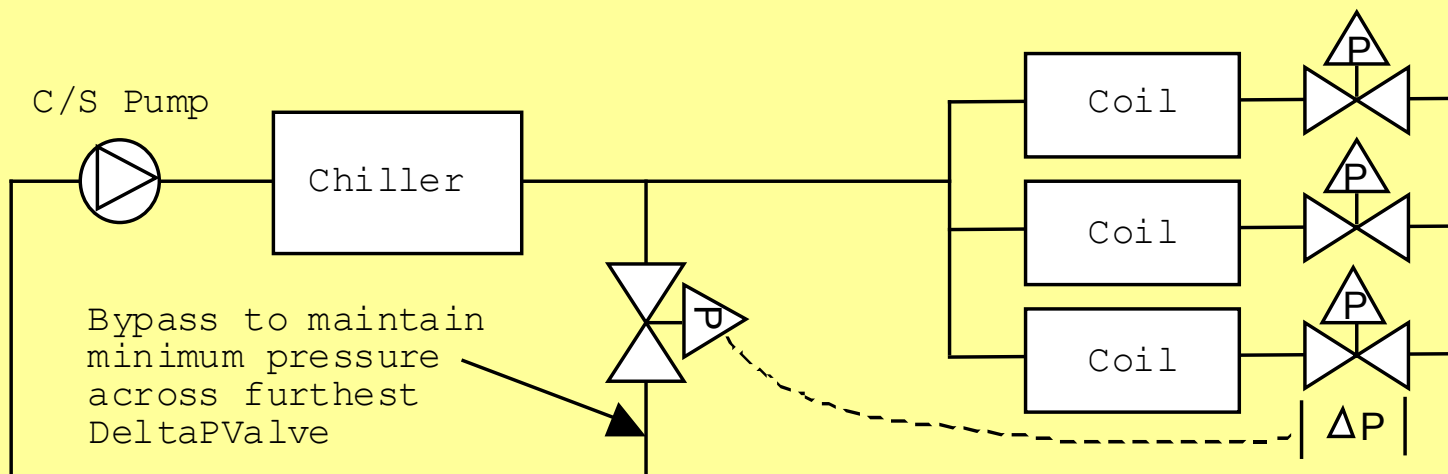
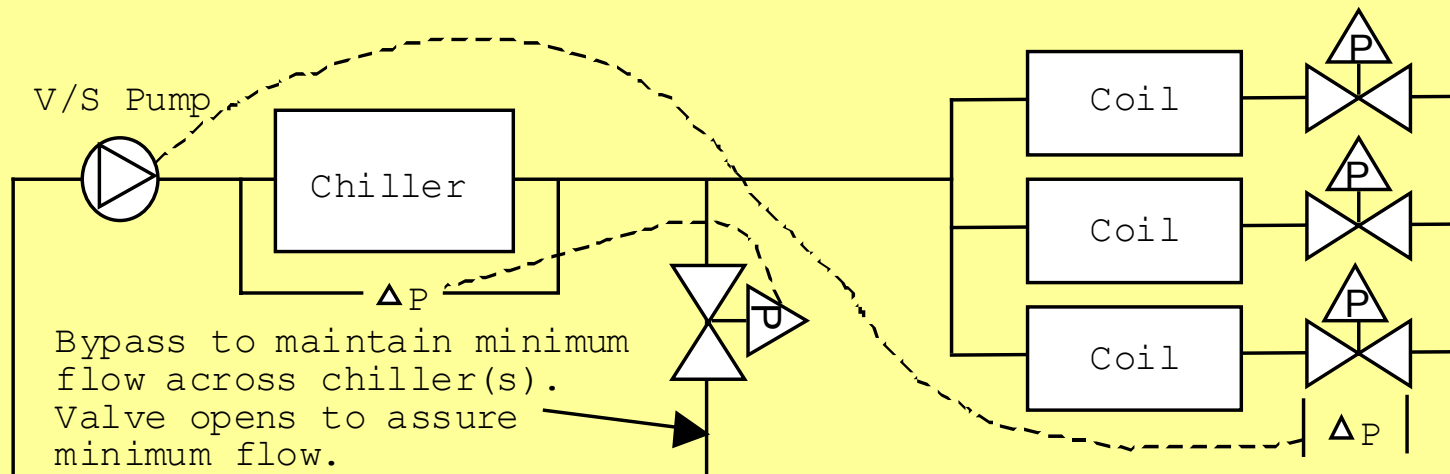

Figure A3: Buildings on Large Heating or Cooling Distribution System



Sequence: Upon a requirement for cooling the pump is started. The bypass valve should be open when chiller starts and should close to maintain minimum pressure (typ. 5 psi) across the hydraulically most remote DeltaP Valve.

Figure A4: Small Chiller System - Constant Speed Pump



Sequence: Upon a requirement for cooling the pump is started. The variable speed drive ramps up to maintain minimum pressure (typ. 5 psi) across the hydraulically most remote valve(s). The bypass valve opens (if required) to maintain minimum flow through the chiller(s).

Note: Bypass valve is sized to maintain the minimum flow as determined by the chiller manufacturer.

Figure A5: Small Chiller System - Variable Speed Pump

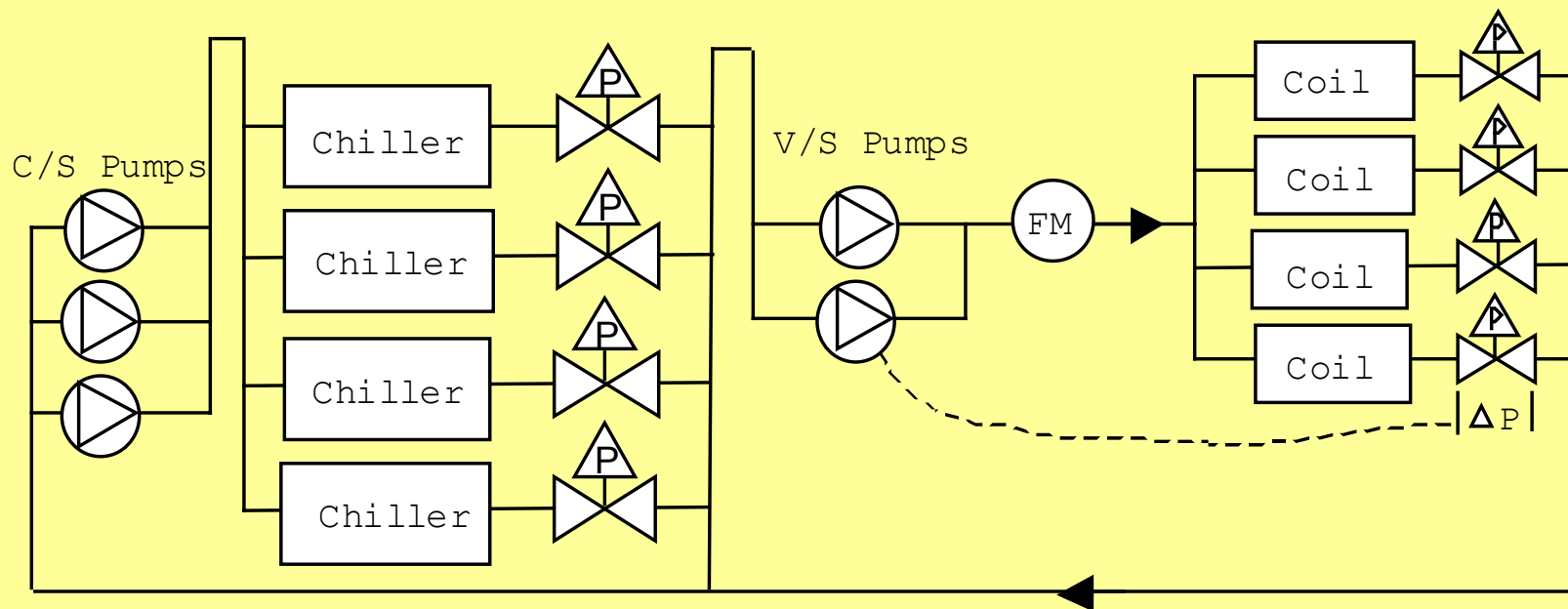

Sequence: On call for cooling open DeltaPValve on lead chiller, start one of the primary pumps and then start lead chiller. The valve will set the maximum design flow through the chiller. The valves on the chillers can be modulated to control flow through the chillers when they are running at part load. Sequence the chillers and primary pumps by measuring the flow to the system. Secondary variable speed pumps maintain minimum pressure (typ. 5 psi) across the hydraulically most remote valve(s).

Note: Multiple delta P sensors may be required on large systems to establish the hydraulically most remote point.

Figure A6: Large Chiller Plant – Primary/Secondary Pumping

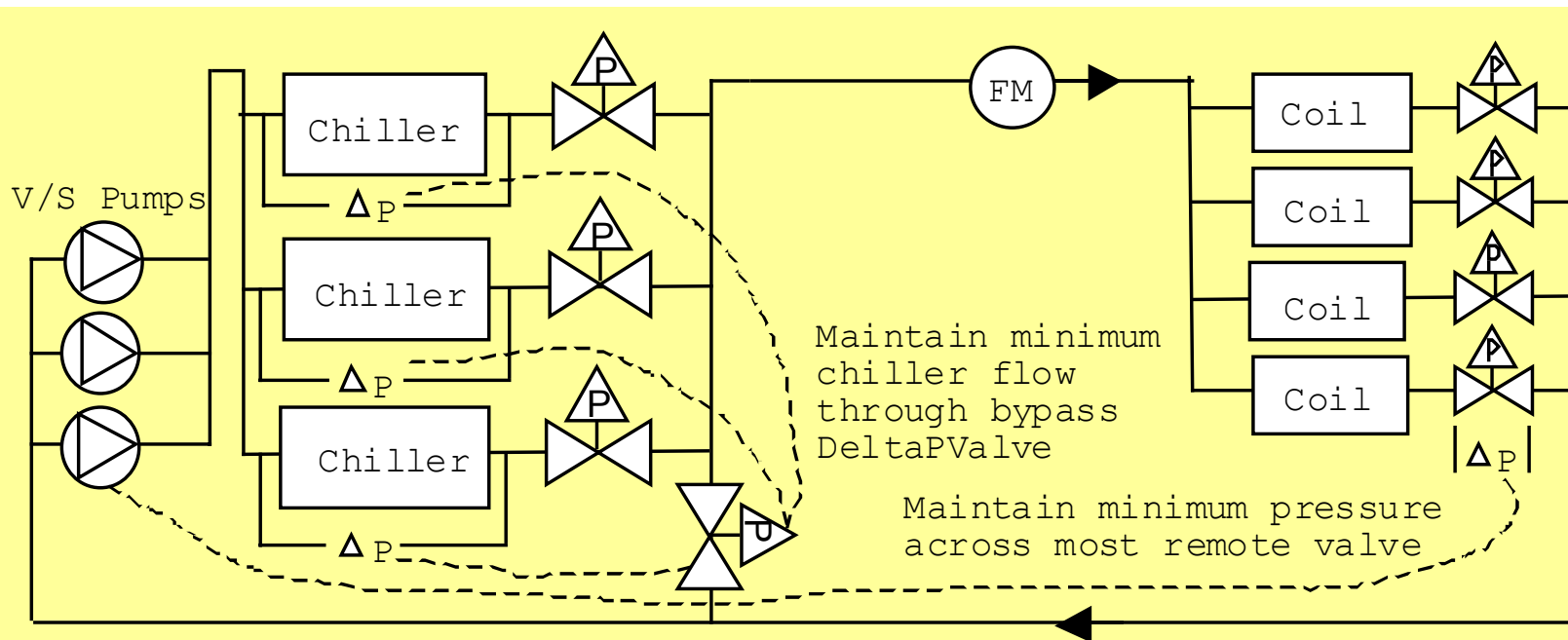

Sequence: On call for cooling open DeltaP Valve on lead chiller to wide open position, start the lead pump. Measure flow to system with the flow meter. Start and stop pumps and chillers as required to maintain flow to meet load with a minimum pressure (typ. 5 psi) across the hydraulically most remote valve(s). At any load the bypass valve is used to maintain minimum flow through any of the chillers.

Note: Use a high quality flow meter (important not to skimp on this device).

Figure A7: Large Chiller Plant – Primary Variable Flow

Do not use on existing buildings with large AHU's, instead put DeltaPValves on the coils.

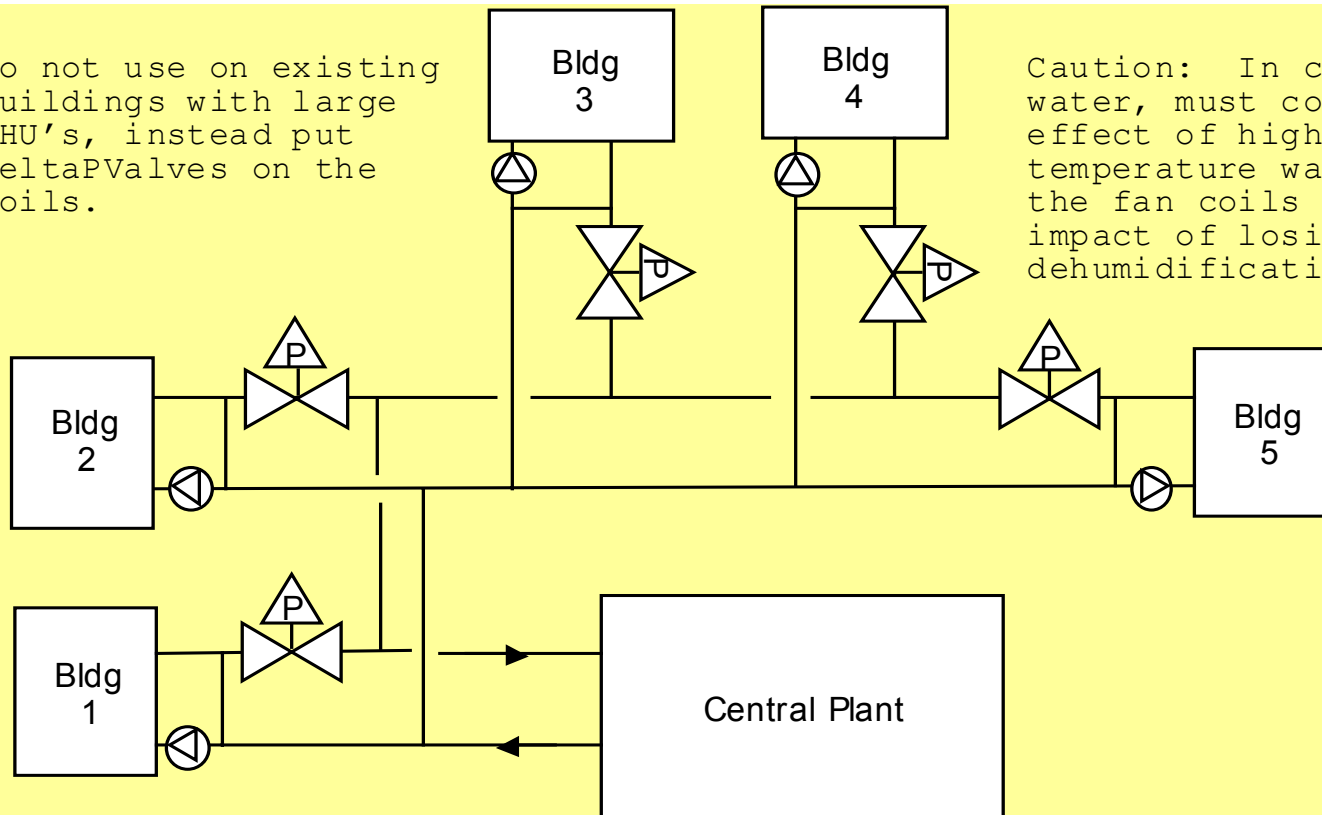

Caution: In chilled water, must consider effect of higher supply temperature water to the fan coils and impact of losing dehumidification.

For the highest delta T, the ideal application of DeltaPValves is on the terminal units in the buildings.

This is a good tool to fix low delta T's in buildings in existing systems that have scores of small terminal units (eg. dormitories with FCU's). New buildings should install DeltaPValves on the terminal units. NEW BUILDINGS SHOULD NOT BE DECOUPLED.

Figure A8: Typical Campus Piping Schematic – Decoupled Buildings – With Many Small FCU's

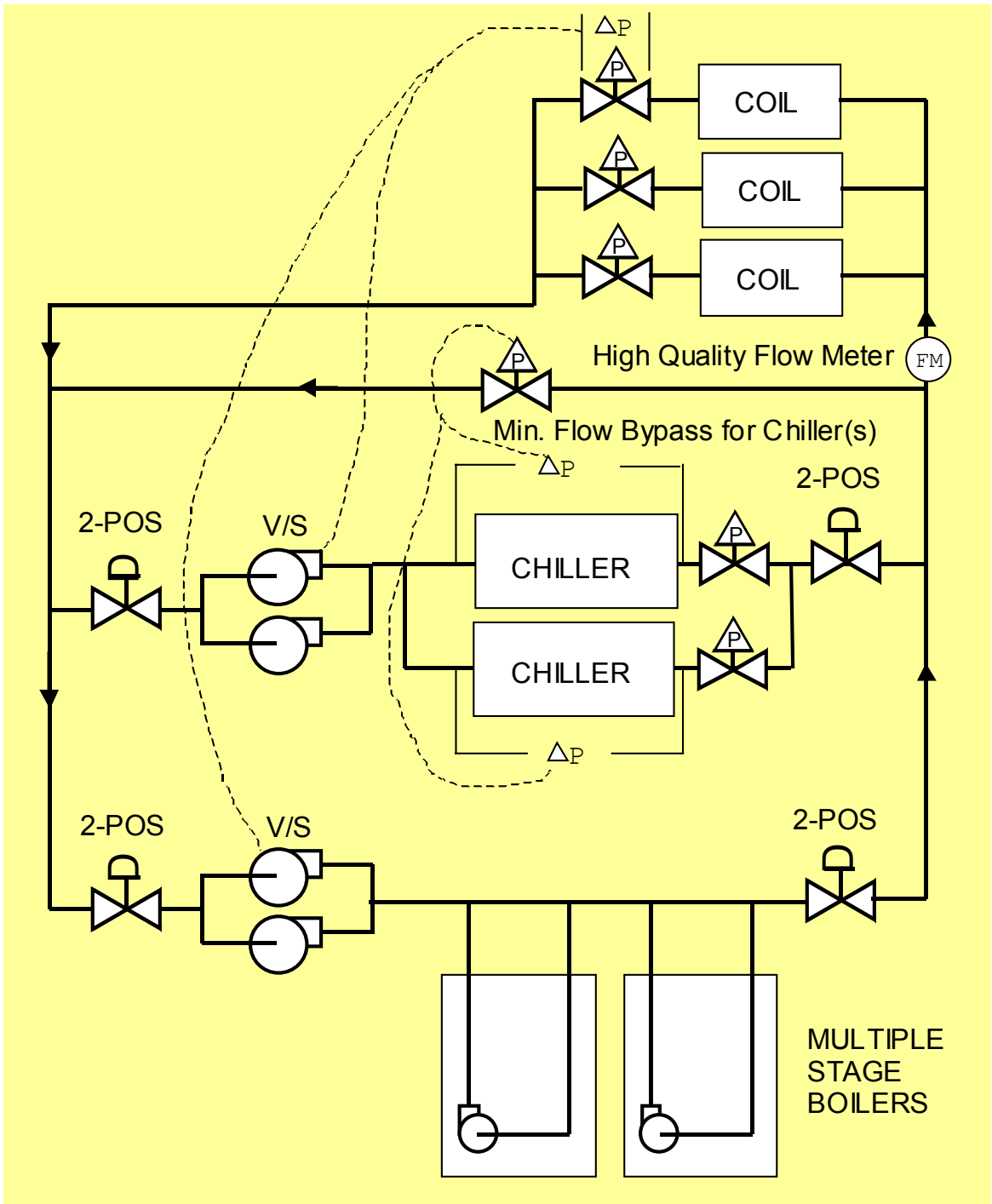
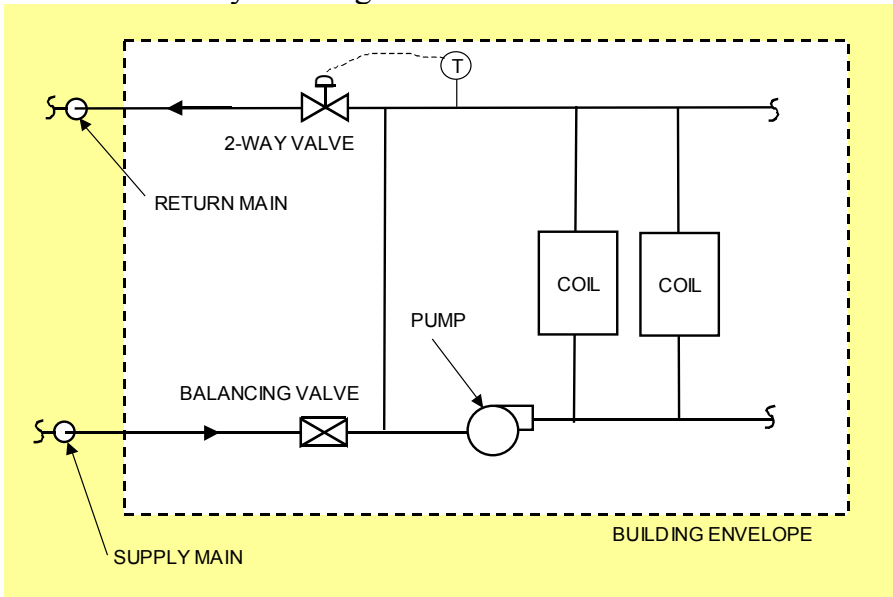

Figure A9: Two-Pipe Changeover System – Excellent System for Schools

EXISTING CONFIGURATION – Excess flow and low delta T due to in-line pump and chilled water return blending with supply. Wastes pump energy and creates humidity problems for the laboratory building.



NEW CONFIGURATION – Minimum flow and design delta T or higher guaranteed at all load conditions (when chilled water is supplied at design or below and supply air temperature is set at design or above). Pump energy dramatically reduced due to bypass and high delta T. Humidity issues are solved. DeltaP Valve flow is controlled with thermostat.

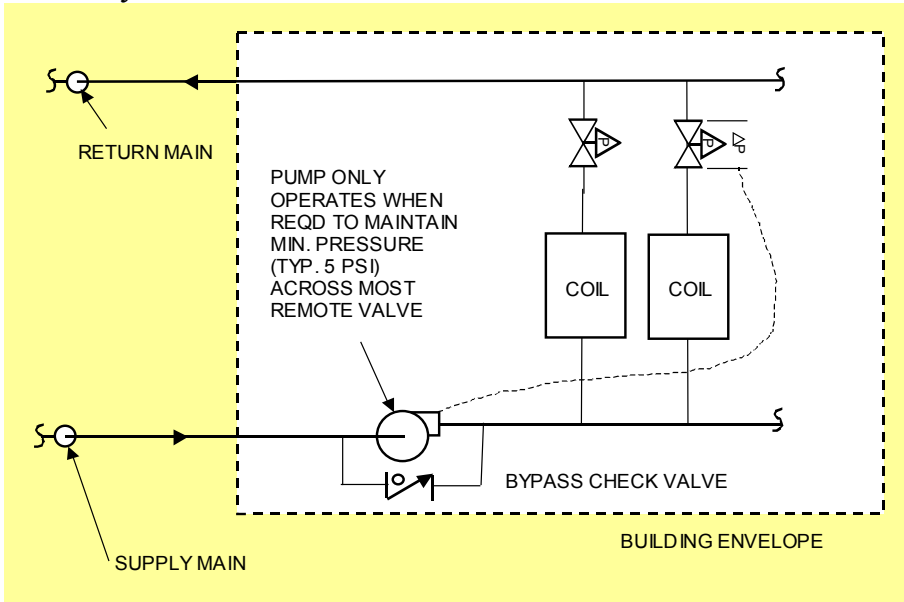

Figure A10: To Address Humidity Issues in Decoupled Laboratory, Hospital, and Other Buildings